

### PROBLEM 3.76

KNOWN: Data are provided for water in a piston-cylinder assembly undergoing two processes in series: constant-pressure followed by constant-volume.

FIND: For the overall process find  $W$  and  $Q$ .

SCHEMATIC & GIVEN DATA:

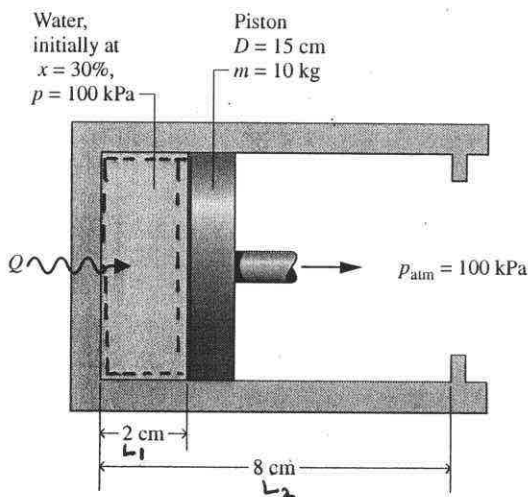
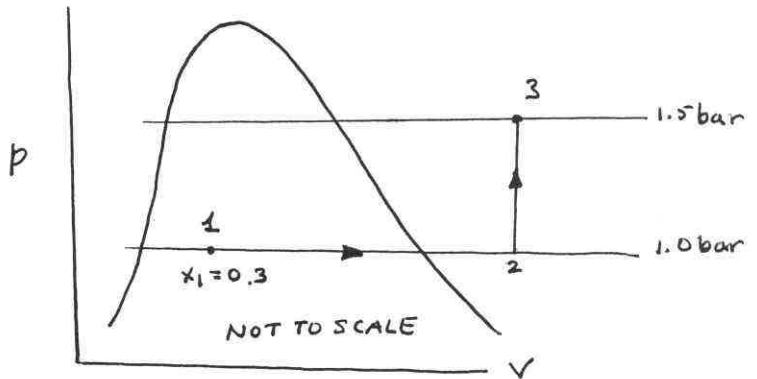

Fig. P3.70



ENGR. MODEL:

1. The water in the piston-cylinder assembly is the system.
2. Friction and kinetic and potential energy effects are absent.
3. Volume change is the only work mode.

ANALYSIS:

Since volume change is the only work mode, work can be evaluated from Eq. 2.17.

Thus

$$W_{12} = \int_1^2 p dV = p[V_2 - V_1] \quad (1)$$

Note that  $W_{23} = 0$  because there is no piston motion (Volume is constant).

An energy balance for the overall process reads:

$$(u_3 - u_1) + \Delta KE + \Delta PE = Q_{13} - W_{13} \Rightarrow Q_{13} = m(u_3 - u_1) + W_{13} \quad (2)$$

Need  $V_1, V_2, m, u_1, u_3$

$$\Rightarrow V_1 = \frac{\pi D^2}{4} L_1 = \frac{\pi (0.15 \text{ m})^2 (0.02 \text{ m})}{4} = 3.53 \times 10^{-4} \text{ m}^3$$

$$\Rightarrow V_2 = \frac{\pi D^2}{4} L_2 = \frac{\pi (0.15 \text{ m})^2 (0.08 \text{ m})}{4} = 1.414 \times 10^{-3} \text{ m}^3$$

with data from Table A-3,  
 $v_f = v_f + x(v_g - v_f)$   
 $= \frac{1.0432}{10^3} + 0.3 \left[ \frac{1.694 - 1.0432}{10^3} \right]$   
 $= 0.50893 \text{ m}^3/\text{kg}$   
 $\Rightarrow m = \frac{V_1}{v_f} = 6.94 \times 10^4 \text{ kg}$

$$u_1 = u_f + x(u_g - u_f)$$

$$= 417.36 + 0.3(2506.1 - 417.36)$$

$$= 1043.98 \frac{\text{kJ}}{\text{kg}} \leftarrow$$

$$v_3 = v_2 = \frac{V_2}{m} = \frac{1.414 \times 10^{-3}}{6.94 \times 10^4} = 2.03746 \frac{\text{m}^3}{\text{kg}}$$

Interpolating in Table A-4 at 1.5 bar,  $u_3 = 2952.1 \frac{\text{kJ}}{\text{kg}} \leftarrow$

Using Eq. (1),

$$W_{12} = p[V_2 - V_1] = (1 \text{ bar}) \left[ \frac{10^5 \text{ N/m}^2}{1 \text{ bar}} \right] (1.414 - 3.53) \times 10^{-4} \text{ m}^3 \left[ \frac{1 \text{ kJ}}{10^3 \text{ N}\cdot\text{m}} \right]$$

$$= 0.106 \text{ kJ} \quad \leftarrow W$$

Using Eq. (2)

$$Q_{13} = m(u_3 - u_1) + W_{13} = (6.94 \times 10^4 \text{ kg}) (2952.1 - 1043.98) \frac{\text{kJ}}{\text{kg}} + 0.106 \text{ kJ}$$

$$= 1.324 + 0.106 = 1.43 \text{ kJ} \quad \leftarrow Q$$